



International Drilling Services Ltd,
 Carrwood Road, Chesterfield Trading Estate,
 Sheepbridge,
 Chesterfield,
 S41 9QB. UK

Telephone +44 (0) 1246 269911
 Fax +44 (0) 1246 269922

PART NUMBER: PS140

REVISION: 1

DESCRIPTION: 140 Tonne Power Swivel (PS)

MATERIAL: API 5L:X52 & BSEN 10025 S355J2

STANDARD: DNV No. 2.22 Lifting Appliances

DATE OF ISSUE: 02/09/2015

SHEET: 1 OF 1

NOTES:

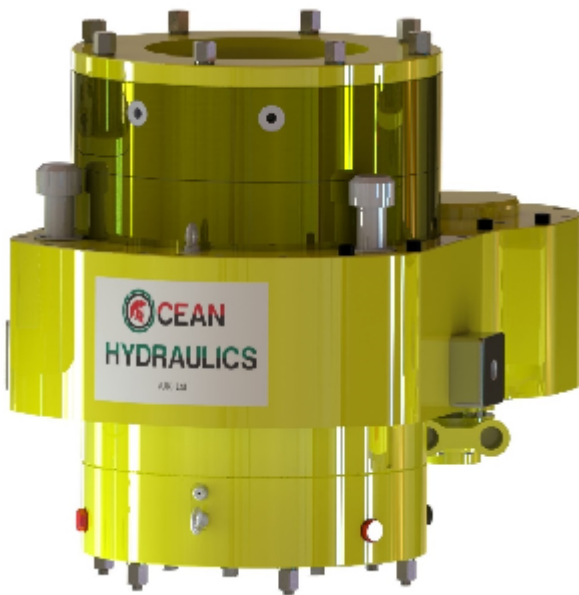
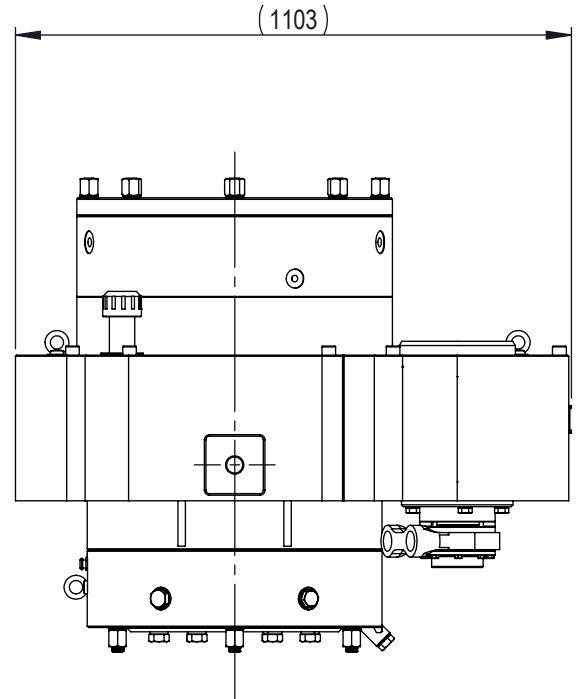
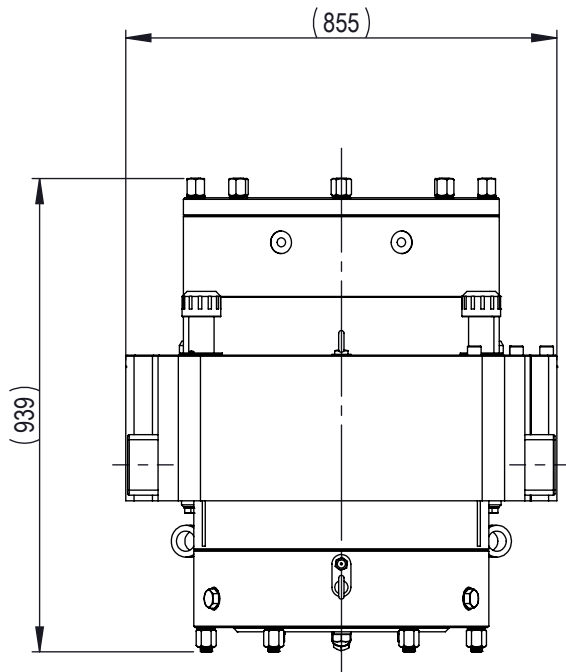

Technical Equipment Specification

SELECTABLE LOGIC CONTROL ON ONE TO FOUR SEGMENT DRIVE
 HYDRAULIC SUPPLY 600LPM @ 300 bar
 MAX TORQUE (4 SEGMENTS) 25,000 Nm @ 50 RPM SPINDLE
 MAX SPEED (1SEGMENT) 8,900 Nm @ 250 RPM SPINDLE
 HOOK LOAD 140 Tonne
 WEIGHT 1.5 Tonne
 MAX TOOL DIA 6"

Parameters Above Are Dependent Upon PS Configuration

Information Presented On This Data Sheet, Shall Not Be Interpreted As An Offer Or Form Any Part Of A Contract