



International Drilling Services Ltd,
Carrwood Road, Chesterfield Trading Estate,
Sheepbridge,
Chesterfield,
S41 9QB. UK

Telephone +44 (0) 1246 269911
Fax +44 (0) 1246 269922

PART NUMBER: E100

REVISION: 01

DESCRIPTION: Pipe Handling Elevator - (100 Tonne)

MATERIAL: API 5L:X52 & BSEN 10025 S355J2

STANDARD: DNV No. 2.22 Lifting Appliances

DATE OF ISSUE: 02/09/2015

SHEET: 1 OF 1

NOTES:

OPEN

CLOSED

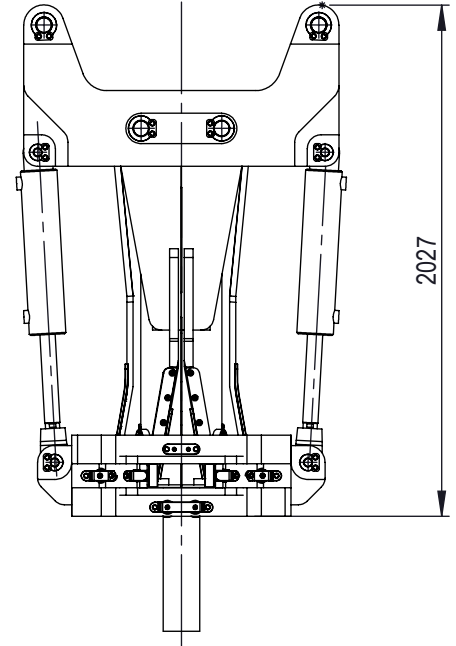
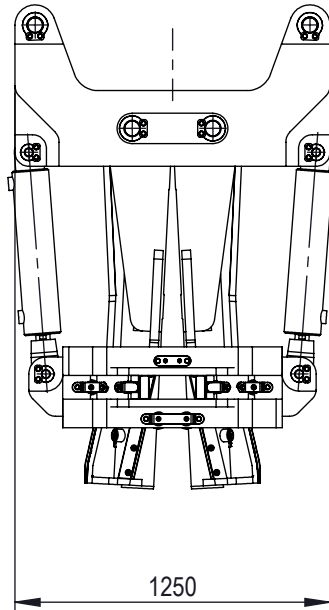
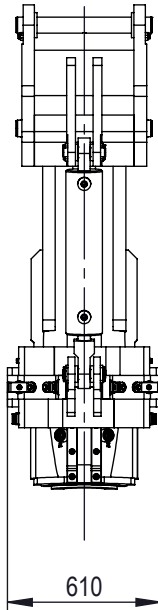

Technical Equipment Specification

HYDRAULIC SUPPLY 50LPM @ 200 bar
MAX VERTICAL SWL 100 TONNE
MAX HORIZONTAL BENDING MOMENT 10 TONNE M
WEIGHT 1.86 Tonne
MAX DRILL STRING DIA 8.5"

Duty Cycle (Sub Sea Drilling):

- 1) Operational Cycle Site: 2.5 Days
- 2) Opening/Closing Site: 250 cycles
Over 2 Periods of 2hrs each
- 3) Ram Speed: Less Than 0.05m/sec
- 4) Sites/Operation: 12-15
- 5) Utilisation: 200 Days/Year

Parameters Above Are Dependent Upon PS Configuration

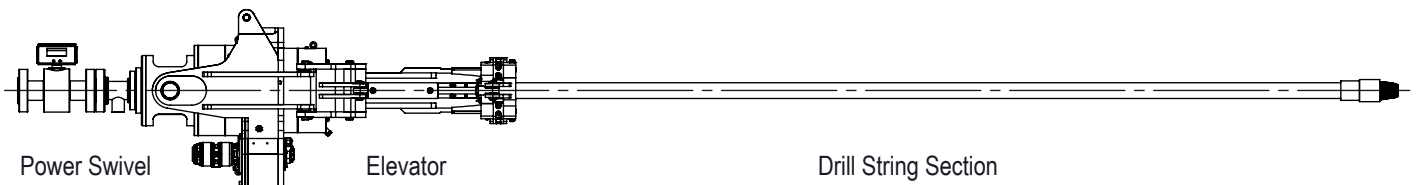

Information Presented On This Data Sheet, Shall Not Be Interpreted As An Offer Or Form Any Part Of A Contract

COMPILED BY: SJC

CHECKED BY: MC